



DEL Packaging, Ltd

Membrane Heat Sealer | Model: MHS-120

Membrane Heat Sealer - 120

This machine is designed to apply foil or plastic membranes to composite/plastic canisters, tubs and containers. Containers are timed into captivator-blocks by mean of a timing screw. The blocks and screw index the containers to a sealing station where the container is grasped and supported by a heavy duty clamping mechanism. A rotary die-cutter completely cuts the membrane patch from the web and the patch is transferred independently by a vacuum transfer system and attached to the conduction sealing heads by vacuum. This method of cutting and transferring the membrane patch ensures a very accurate membrane placement and reduces film waste to an absolute minimum. Heavy-duty air cylinders apply the pressure necessary for a hermetic seal.

Applications

- Round and non-round containers
- Rigid or fragile container designs
- Foil and plastic materials
- Composite, metal, glass and blow-molded containers
- 2" - 6 1/2" diameter containers
- 2" - 12" height containers

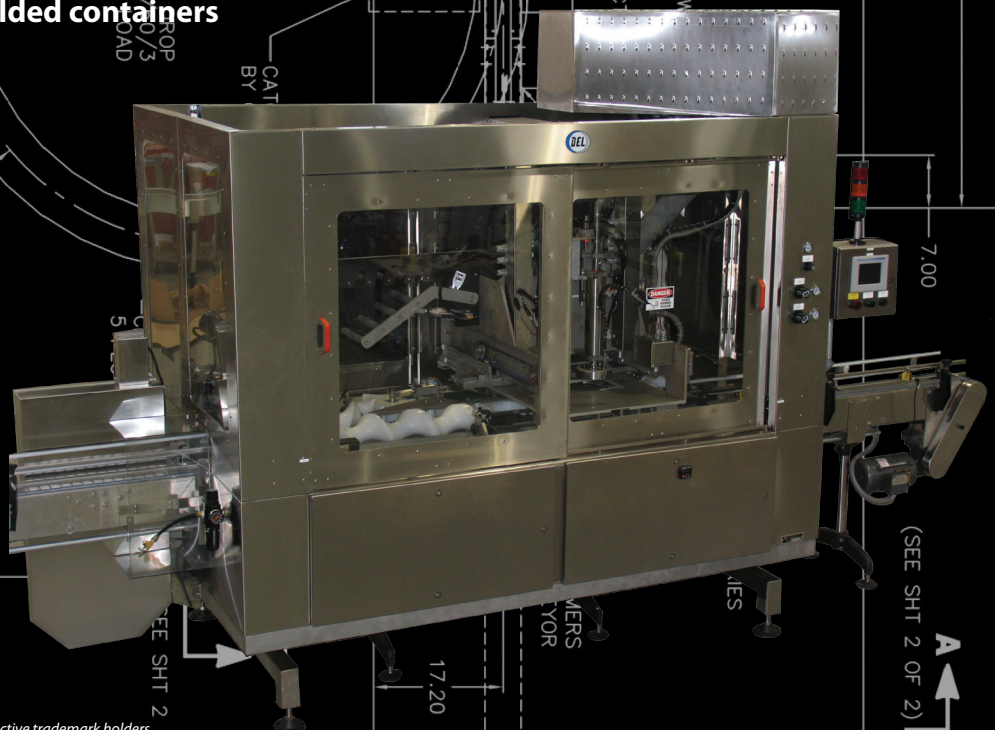

Experience the DEL Difference

Specifications

- Up to 120 containers per minute
- Dual-timing screw in-feed
- Vacuum-film waste removal system
- Stainless steel (non-wash down) construction
- Mechanical container diameter adjustment
- Ethernet and communications modules
- Vacuum-film transfer technology
- Variable speed capability without affecting heat-seal
- Servo-controlled rotary-die and vacuum transfer system for membrane
- 460 Volt / 60 Hertz / 3 Phase NEMA 12 DC Electrical

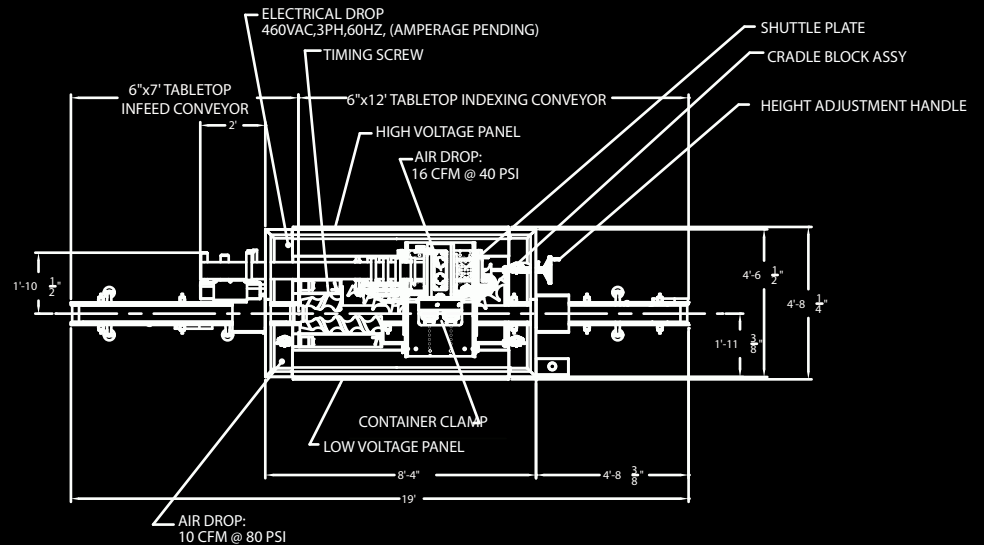

Available Options

- Wash-down design
- Soft-reject (film-splice and offset-seal detection)
- Leak detection (Gross to Micro Leaks)
- Modified atmosphere packaging (nitrogen gassing)
- Laser-print capabilities for seal-head identification
- All domestic and international voltages to meet UL and CE requirements)

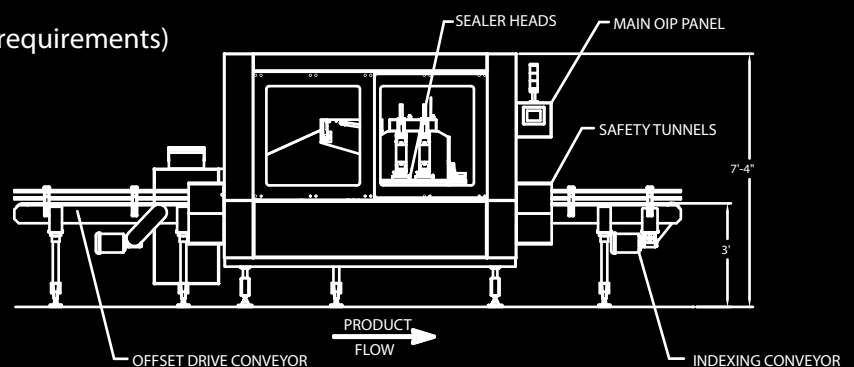
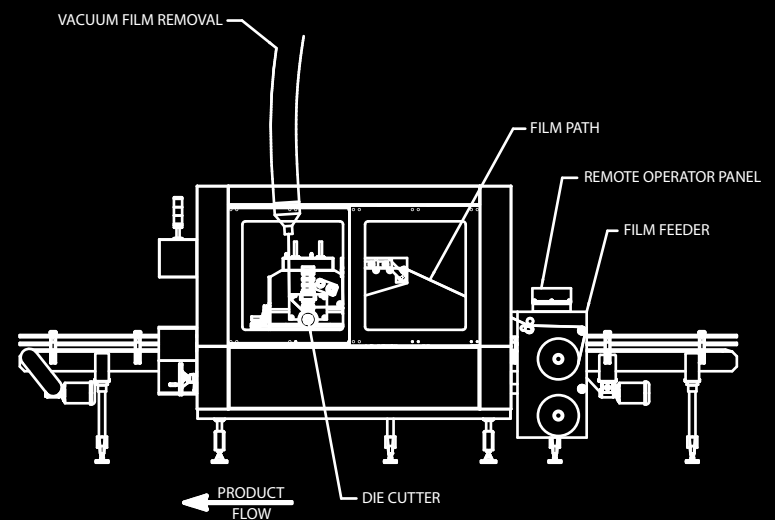

Contact DEL Packaging, Ltd

18113 Telge Road | Cypress, TX 77429
 Phone: 281.653.0099 | Fax: 281.653.0082
<http://www.delpackaging.com> | sales@delpackaging.com



Membrane Heat Sealer | MHS-120