



# DEL Packaging, LTD.

Experience the DEL difference and you'll be in good company.

*Manufacturing packaging machinery since 1938.*

## Induction Sealers | *Model: CMIS*

### Continuous Motion Induction Sealer

DEL's continuous motion induction sealer features a timing screw infeed, rotary turret, cam actuated induction sealing heads, rotary die cutter, and a very unique vacuum transfer conveyor that transfers the pre-cut membrane to the induction sealing head. This system very accurately applies a membrane to a container with virtually no excess membrane around the perimeter of the container.

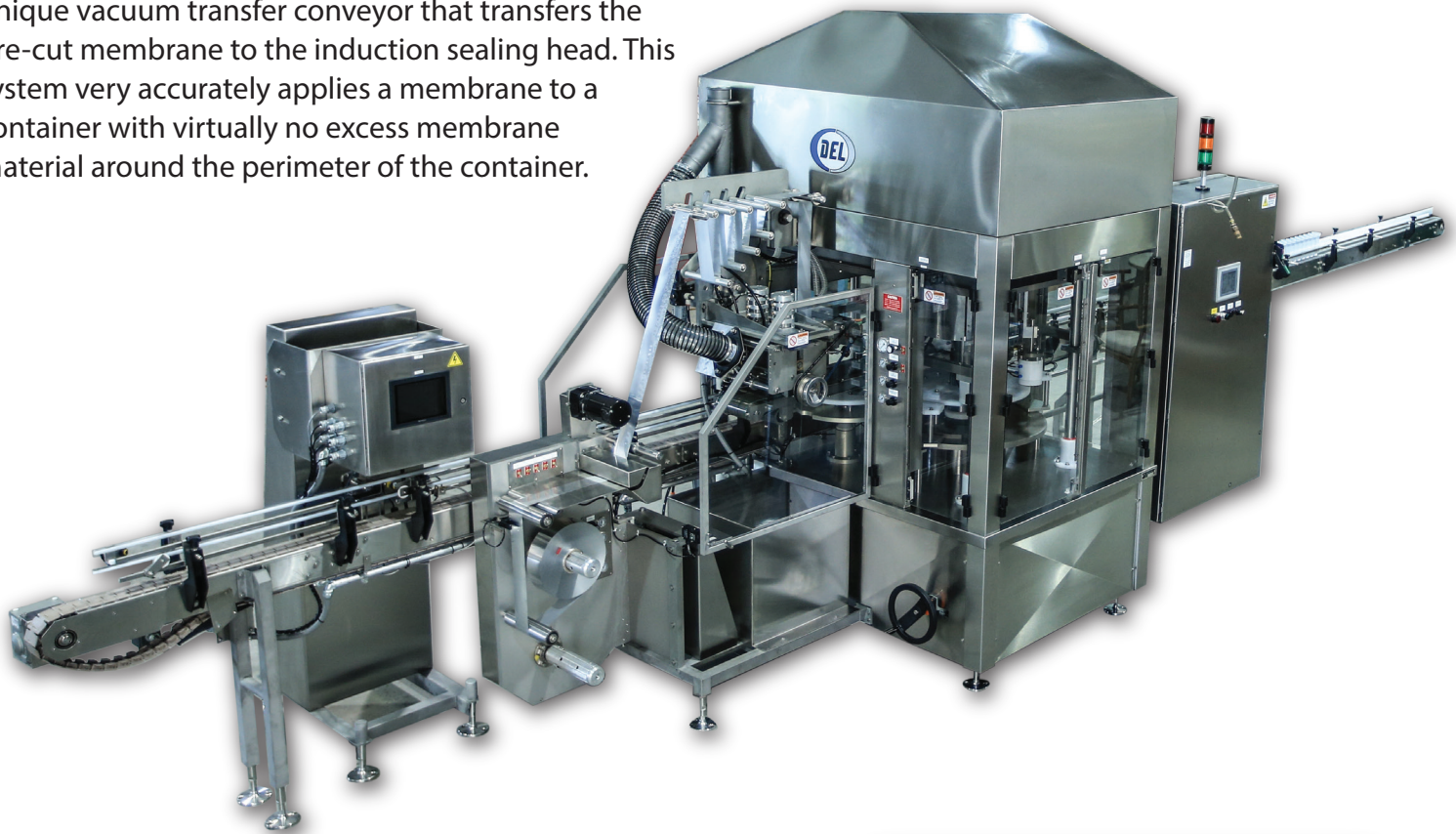

### Applications

- Metalized roll stock membrane materials
- Tapered or straight-walled containers
- Plastic, metal or composite containers
- 2" – 6.5" diameter containers
- 2" - 12" height containers
- Round, square or oval shape containers



# Experience the DEL Difference

## Specifications

- 60 to 350 containers per minute (contingent upon size of container)
- Stainless steel, non-wash down construction (standard)
- 440/60/3 power
- Designed for multiple size containers (precision change-over) with tooling

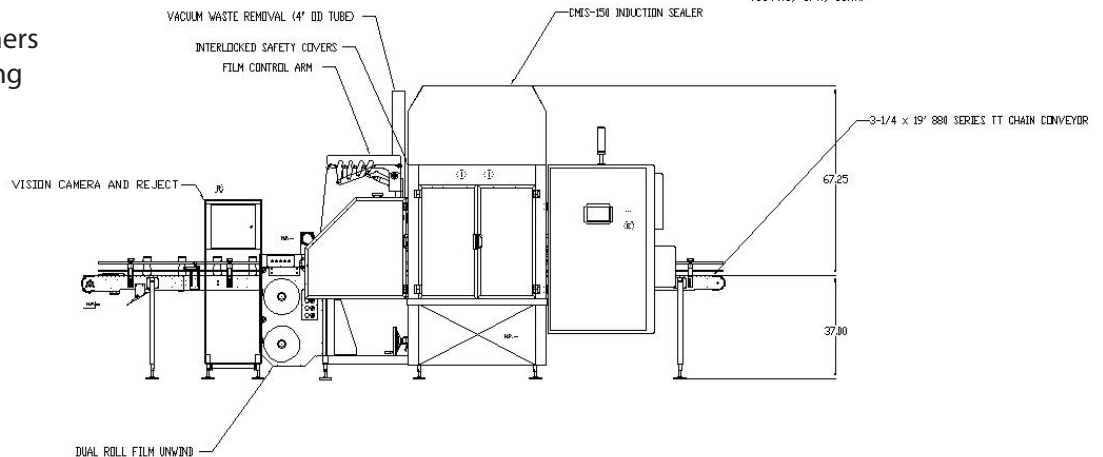
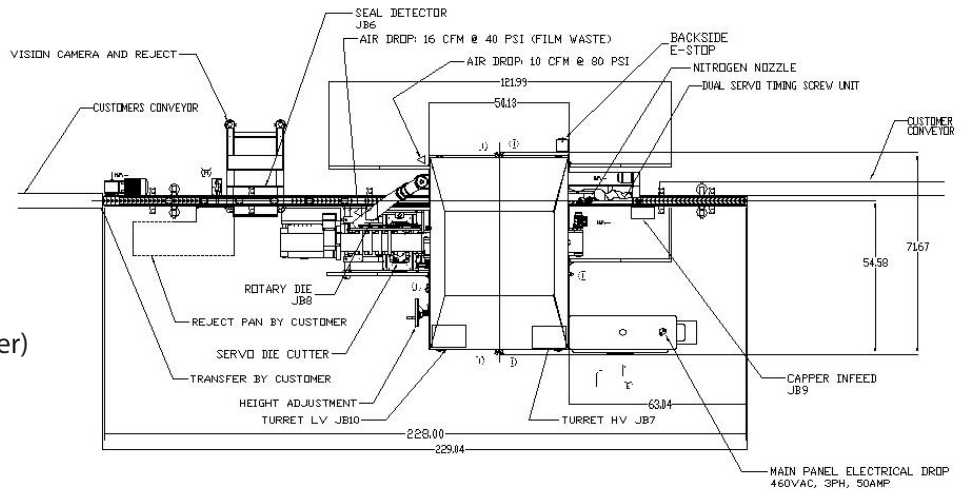

## Available Options

- Stainless steel, wash-down construction
- Servo height adjustment
- Conveyors (table top chain)

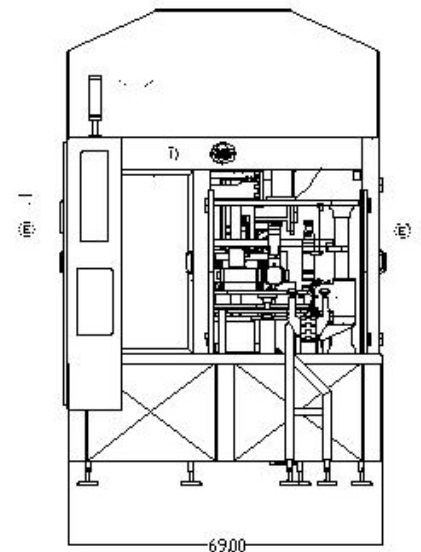
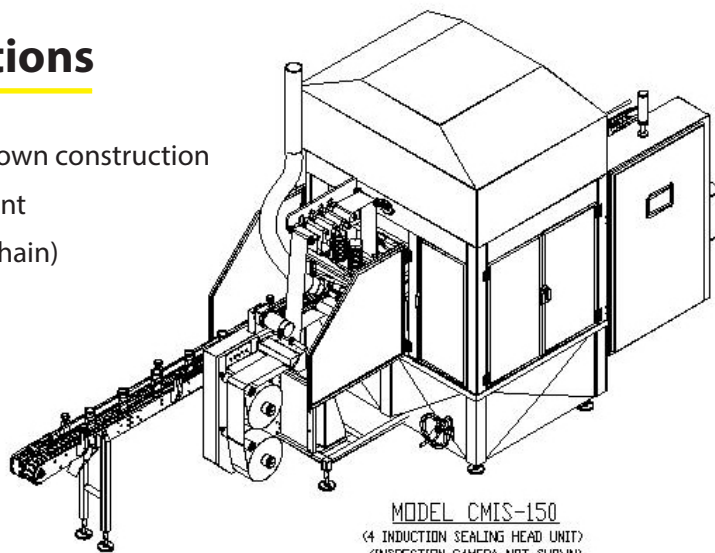

## Contact DEL Packaging, Ltd

18113 Telge Road | Cypress, TX 77429  
 Phone: 281.653.0099 | Fax: 281.653.0082  
<http://www.delpackaging.com> | [sales@delpackaging.com](mailto:sales@delpackaging.com)



Induction Sealers | Model: CMIS